

# Questions and Answers about Infrared Thermometry

## 1. Why use noncontact infrared thermometers?

Noncontact infrared (IR) thermometers use infrared technology to quickly and conveniently measure the surface temperature of objects. They provide fast temperature readings without physically touching the object. You simply aim, pull the trigger and read the temperature on the LCD display.

Lightweight, compact and easy-to-use, IR thermometers can safely measure hot, hazardous or hard-to-reach surfaces without contaminating or damaging the object. Also, infrared thermometers can provide several readings per second as compared to contact methods where each measurement can take several minutes.

## 2. How does IR work?

IR thermometers capture the invisible infrared energy naturally emitted from all objects. Infrared radiation is part of the electromagnetic spectrum, which includes radio waves, microwaves, visible light, ultraviolet, gamma and x-rays.

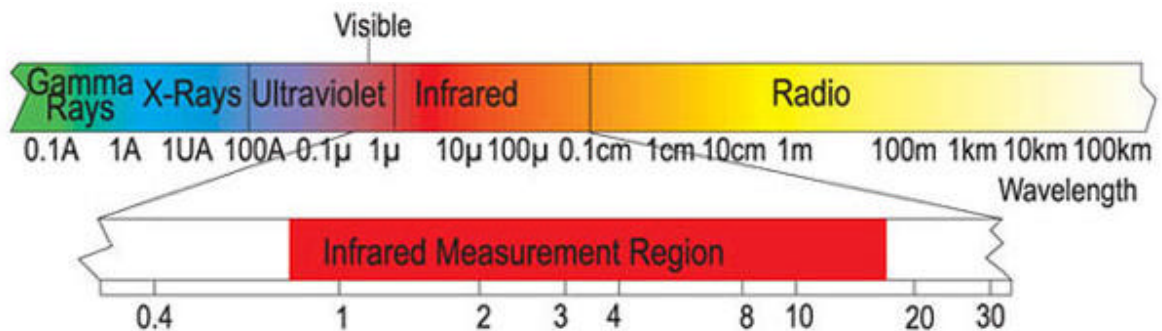

Infrared falls between the visible light of the spectrum and radio waves. Infrared wavelengths are usually expressed in microns, with the infrared spectrum extending from 0.7 microns to 1000 microns. In practice, the 0.7 to 14 micron band is used for IR temperature measurement.

## 3. How to assure accurate temperature measurement

A solid understanding of infrared technology and its principles lies behind accurate temperature measurement. When the temperature is measured by a non-contact device, the IR energy emitted from the measured object passes through the optical system of the thermometer and is converted to an electrical signal at the detector. This signal is then displayed as a temperature reading. There are several factors that determine accurate measurement. The most important factors are emissivity, field of view, distance to spot size and location of the hot spot.

**Emissivity.** All objects reflect, transmit and emit energy. Only the emitted energy indicates the temperature of the object. When IR thermometers measure the surface temperature they sense all three kinds of energy; therefore, all thermometers have to be adjusted to read emitted energy only. Measuring errors are often caused by IR energy being reflected by light sources.

Some IR thermometers allow you to change the emissivity in the unit. The value of emissivity for various materials can be looked up in published emissivity tables.

Other units have a fixed, pre-set emissivity of 0.95, which is the emissivity value for most organic materials and painted or oxidized surfaces. If you are using a thermometer with a fixed

emissivity to measure the surface temperature of a shiny object, you can compensate by covering the surface to be measured with masking tape or flat black paint. Allow time for the tape or paint to reach the same temperature as the material underneath. Measure the temperature of the taped or painted surface. This is the true temperature.

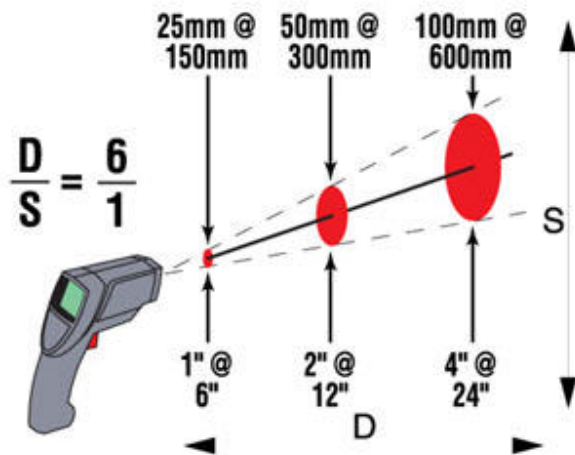
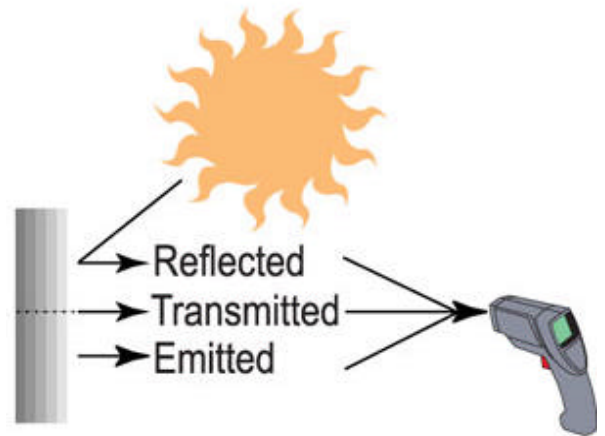

**Distance to spot ratio:** The optical system of an infrared thermometer collects the infrared energy from a circular measurement spot and focuses it on the detector. Optical resolution is defined by the ratio of the distance from the instrument to the object being measured (D:S ratio). The larger the ratio number the better the instrument's resolution, and the smaller the spot size that can be measured. The laser sighting included in some instruments only helps to aim at the measured spot.

A recent innovation in infrared optics is the addition of a Close Focus feature, which provides accurate measurement of small target areas without including unwanted background temperatures.

**Field-of-view:** Make sure that the target is larger than the spot size the unit is measuring. The smaller the target, the closer you should be to it. When accuracy is critical, make sure that the target is at least twice as large as the spot size.

#### 4. How to take a temperature measurement

To take a temperature measurement, just point the unit at the object you wish to measure, pull the trigger and read the temperature on the unit's LCD. Be sure to consider distance-to-spot size ratio and field-of-view. There are important things to keep in mind while using infrared thermometers:

**Measure the surface temperature only:** The IR thermometer cannot measure internal temperatures.

**Do not take temperature measurements through glass:** Glass has very distinctive reflection and transmission properties that do not allow accurate infrared temperature readings. Infrared thermometers are not recommended for use in measuring shiny or polished metal surfaces (stainless steel, aluminium, etc.). (See Emissivity)

**Locate a hot spot:** To find a hot spot aim the thermometer outside the area of interest, then scan across with an up and down motion until you locate the hot spot.

**Watch for environmental conditions:** Steam, dust, smoke, etc., can prevent accurate measurements by obstructing the unit's optics

**Ambient Temperatures:** If the thermometer is exposed to abrupt ambient temperature differences of 20 degrees or more, allow it to adjust to the new ambient temperature for at least twenty minutes.

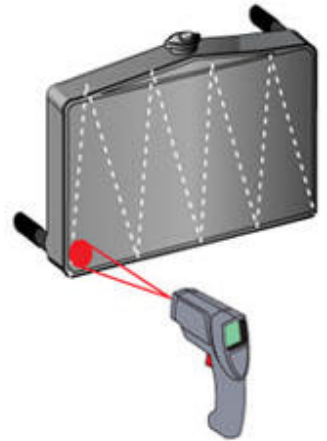

## 5. What are the most popular applications?

Non-contact thermometers have many uses. The most popular include:

**Automotive:** Diagnose cylinder heads and heating and cooling systems, **HVAC:** Monitor air stratification, supply/return registers and furnace performance, **Electrical:** Check defective transformers, electrical panels and connectors, **Food Safety:** Scan holding, serving and storage temperatures, **And more:** hundreds of recreational, work and home applications.